

REVISIONS					
REV.	DATE	ECN #	DESCRIPTION	BY	APPROVED
1	5/19/2009		STUD MATERIAL WAS "COPPER C11000 TIN PLATED."	JH	JFS
2	9/18/2009		ADDED DIMENSION.	JH	
3	9/22/2009	HJ09-153	.56" WAS .46"	JH	JFS
4	10/15/2009	HJ09-165	REMOVED BAYONET LOCK; .58" WAS .56".	JH	JFS

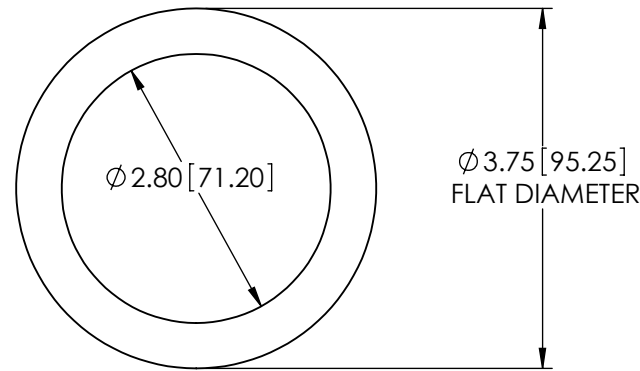

TANK HOLE DIMENSIONS
(DIMENSIONS ARE REFERENCE ONLY)

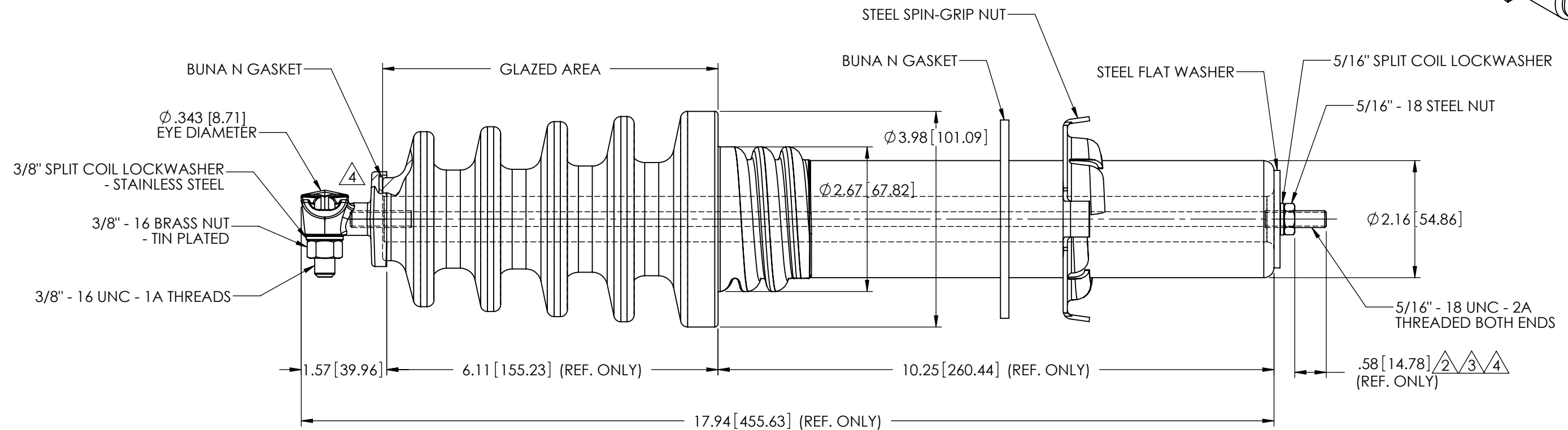
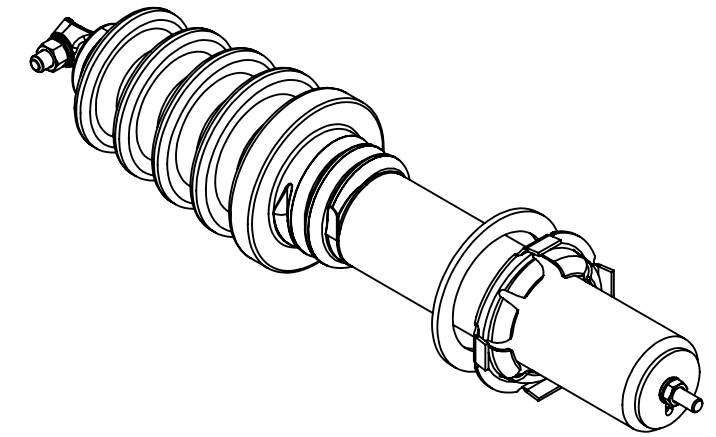
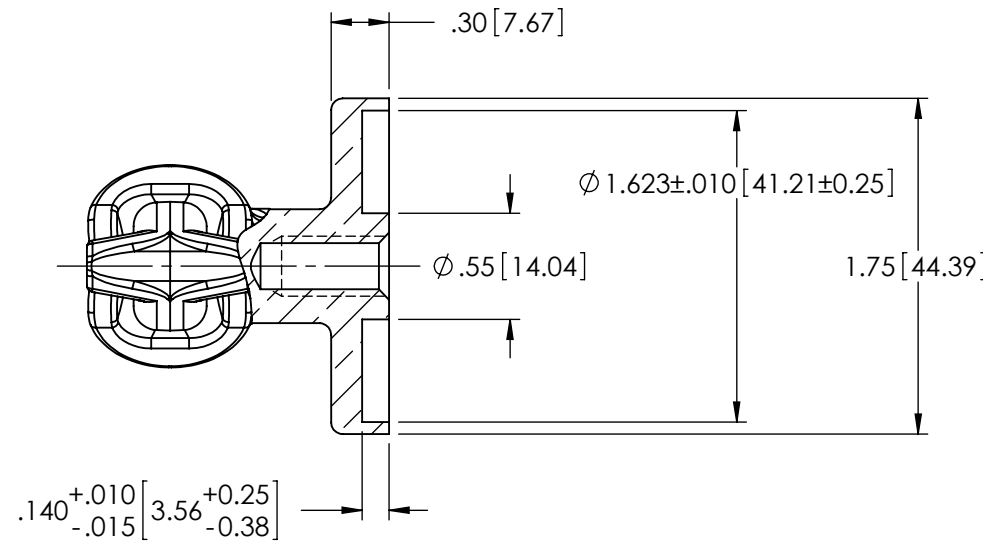

1 MATERIAL:
 1. STUD - 1008-1010 STEEL ROD PHOSPHATIZED
 2. TERMINAL BODY - C84400 TIN PLATED

PORCELAIN NOTES:
 1. WET PROCESS ELECTRICAL PORCELAIN.
 2. GREY GLAZE MUNSELL 5BG 7.0/0.4
 3. TOLERANCE ±3% WITH NOTHING LESS THAN ±.03".

SPECIFICATIONS:
 1. RATED VOLTAGE.....15kV
 2. BASIC IMPULSE LEVEL.....95kV
 3. STRIKE DISTANCE.....6.11" [155.23mm]
 4. CREEP DISTANCE(MIN.).....11.00" [279.40mm]
 5. APPROXIMATE WEIGHT.....6.6 LBS

PROPRIETARY AND CONFIDENTIAL
 THE INFORMATION CONTAINED IN THIS DRAWING IS THE SOLE PROPERTY OF H-J ENTERPRISES, INC. ANY REPRODUCTION IN PART OR AS A WHOLE WITHOUT THE WRITTEN PERMISSION OF H-J ENTERPRISES, INC. IS PROHIBITED.

TOLERANCES (EXCEPT AS NOTED)	
DECIMAL	+/- .032"/.8mm
FRACTIONAL	+/-
ANGULAR	+/- 2 Degrees



H-J ENTERPRISES, INC.
 3010 HIGH RIDGE BLVD. HIGH RIDGE, MO. 63049 USA
 PHONE 1-636-677-3421 FAX 1-636-376-1915

15 kV 95 kV BIL H.V. BUSHING ASSEMBLY

MATERIAL (SEE DRAWING)

DRAWN BY JH DATE 3/18/2009 SCALE N.T.S.

DRAWING NO. AS1598-001